



Glass Panel Installation Instructions

For AZEK Trademark and AZEK Premier Railing

Read ALL instructions completely before installation. Each railing kit comes complete with all parts, hardware and installation guide to install one complete rail section (EXCLUDING POSTS, CAPS and GLASS) and have been pre-cut to 6 ft. lengths. Check to ensure the kit is complete.

SAFETY: Always wear goggles when cutting, drilling and fastening materials

NOTE: Check local building code requirements.

FOLLOW STEPS 1 THROUGH 4 OF THE AZEK PREMIER AND AZEK TRADEMARK INSTALLATION GUIDE.

Step 5 CENTER SUPPORT

Place the center support at the mid point of the Bottom Rail and attach using the 1" drill quick screws supplied (Refer to Figure #5 of the AZEK Premier / AZEK Trademark Installation Guide).

Step 6 INSTALL BOTTOM RAIL

Mark the "T" Bracket hole location on the post sleeves for the Bottom Rail at (3 1/8" for US and 1 1/8" for Canada) above the deck surface. Drill the marked "T" Bracket hole locations using a 13/64" drill bit through the post sleeves. Install the Bottom Rail to the Post Sleeves using (2) of the 2" x #14 stainless steel screws supplied with a #3 square drill bit.

Step 7 INSTALL GLASS PANEL HARDWARE

Mark the glass panel bracket hole locations above the bottom rail, centered on the Post Sleeves at 4 1/2" and 24" for a 36" high rail, or 4 1/2" and 30" for 42" high rail above the top of the Bottom Rail (for Canada, add 2" to the height of the upper glass panel bracket). Using a 13/64" drill bit, drill through the Post Sleeve at the 4 glass panel bracket hole locations and install the 4 glass panel brackets using the 2" x #14 stainless steel screws supplied. Make sure that all brackets face the same direction.

Step 8 INSTALL THE GLASS PANEL

Place 2 of the supplied rubber bumpers in the center of the rail evenly spaced (approx. 6" from each side) on the top of the bottom rail.

Remove the clamping plates from the glass panel brackets. Place the glass against the brackets, ensuring that the glass is centered on the rubber bumpers and in the opening. Reinstall the glass panel bracket clamping plates and tighten the screws accordingly.

Step 9 INSTALL THE HANDRAIL AND RETAINER

With the mounting brackets and retainer already installed and fastened to the handrail, place the remaining 2 rubber bumpers evenly spaced on the underside of the retainer (approx. 6" from each side).

Place the handrail assembly on top of the glass ensuring the rubber bumpers are centered on the glass, and rail is centered on the post sleeve. Mark the bracket hole location and drill the Post Sleeve using a 13/64" drill bit. Using a #3 square drive bit, attach the handrail assembly to the post sleeve using the 2" x #14 stainless steel screws that are supplied. Ensure the rubber bumpers are centered against the glass.

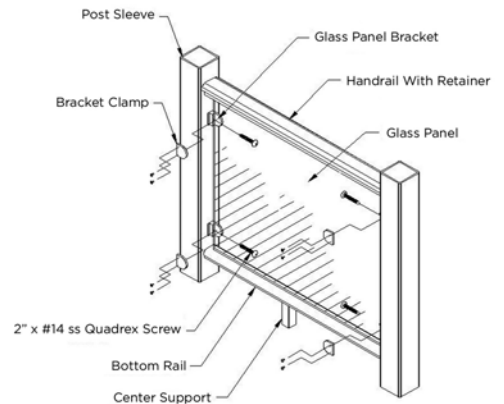

GLASS PANEL SIZING

Ensure the opening is square and plumb. Measure the opening between the posts at the top and bottom to ensure squareness.

THICKNESS: 3/8" Tempered

WIDTH: Subtract 1 3/4" from the opening size to allow room for the brackets and proper clearance.

HEIGHT:	US	36" Rail Height	-----	28 3/8"
		42" Rail Height	-----	34 3/8"
	Canada	36" Rail Height	-----	30 3/8"
		42" Rail Height	-----	36 3/8"

